

FLANGE ADAPTERS

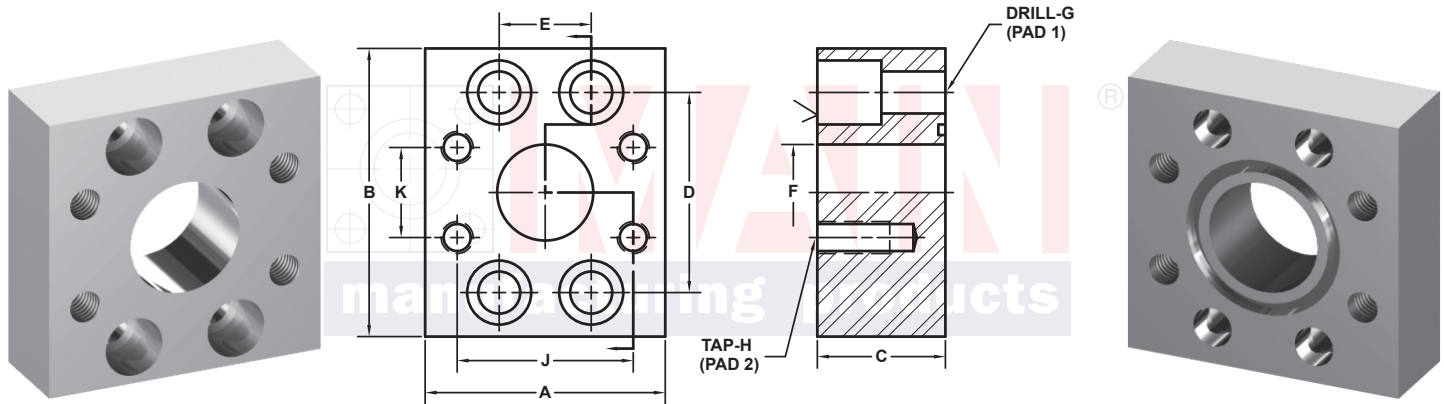

3181 TRI-PARK DR. GRAND BLANC, MI 48439 800-521-7918 810-953-1380 FAX 810-953-1385 INFO@MAINMFG.COM

SAE BOLT PATTERN													62 SERIES TO 61 SERIES ^⑤			
PAD 1 C62	PAD 2 C61	PART NUMBER	A	B	C	D	E	F	G	H	J	K	MOUNTING KIT ^①			
													PART NO.	BOLT SIZE	O-RING	
1/2	1/2	1339-08-08	2.25	2.25	1.00	1.594	.718	.50	.34	5/16-18	1.500	.688	MK 564	5/16-18 x 1	210	
3/4	3/4	1339-12-12	2.75	2.81	1.00	2.000	.937	.75	.41	3/8-16	1.875	.875	MK 565	3/8-16 x 1	214	
3/4	1/2	1339-12-08	2.25	2.81	1.75	2.000	.937	.50	.41	5/16-18	1.500	.688	MK 502	3/8-16 x 1 3/4	214	
1	1	1339-16-16	3.00	3.19	1.25	2.250	1.093	1.00	.47	3/8-16	2.062	1.031	MK 569	7/16-14 x 1 1/4	219	
1	3/4	1339-16-12	2.75	3.19	1.75	2.250	1.093	.75	.47	3/8-16	1.875	.875	MK 513	7/16-14 x 1 3/4	219	
1	1/2	1339-16-08	2.25	3.19	1.75	2.250	1.093	.50	.47	5/16-18	1.500	.688	MK 513	7/16-14 x 1 3/4	219	
1 1/4	1 1/4	1339-20-20	3.25	3.75	1.25	2.625	1.250	1.25	.53	7/16-14	2.312	1.188	MK 570	1/2-13 x 1 1/4	222	
1 1/4	1	1339-20-16	2.75	3.75	1.75	2.625	1.250	1.00	.53	3/8-16	2.062	1.031	MK 529	1/2-13 x 1 3/4	222	
1 1/4	3/4	1339-20-12	2.75	3.75	1.75	2.625	1.250	.75	.53	3/8-16	1.875	.875	MK 529	1/2-13 x 1 3/4	222	
1 1/4	1/2	1339-20-08	2.75	3.75	1.75	2.625	1.250	.50	.53	5/16-18	1.500	.688	MK 529	1/2-13 x 1 3/4	222	
1 1/2	1 1/2	1339-24-24	3.75	4.50	1.50	3.125	1.437	1.50	.66	1/2-13	2.750	1.406	MK 571	5/8-11 x 1 1/2	225	
1 1/2	1 1/4	1339-24-20	3.25	4.50	2.00	3.125	1.437	1.25	.66	7/16-14	2.312	1.188	MK 562	5/8-11 x 2	225	
1 1/2	1	1339-24-16	3.25	4.50	1.75	3.125	1.437	1.00	.66	3/8-16	2.062	1.031	MK 1544	5/8-11 x 1 3/4	225	
1 1/2	3/4	1339-24-12	3.25	4.50	1.75	3.125	1.437	.75	.66	3/8-16	1.875	.875	MK 1544	5/8-11 x 1 3/4	225	
1 1/2	1/2	1339-24-08	3.25	4.50	1.75	3.125	1.437	.50	.66	5/16-18	1.500	.688	MK 1544	5/8-11 x 1 3/4	225	

① Order Separately

⑤ **CAUTION:** Flange adapter pressure rating cannot exceed 61 series pad connection.

FLANGE ADAPTERS

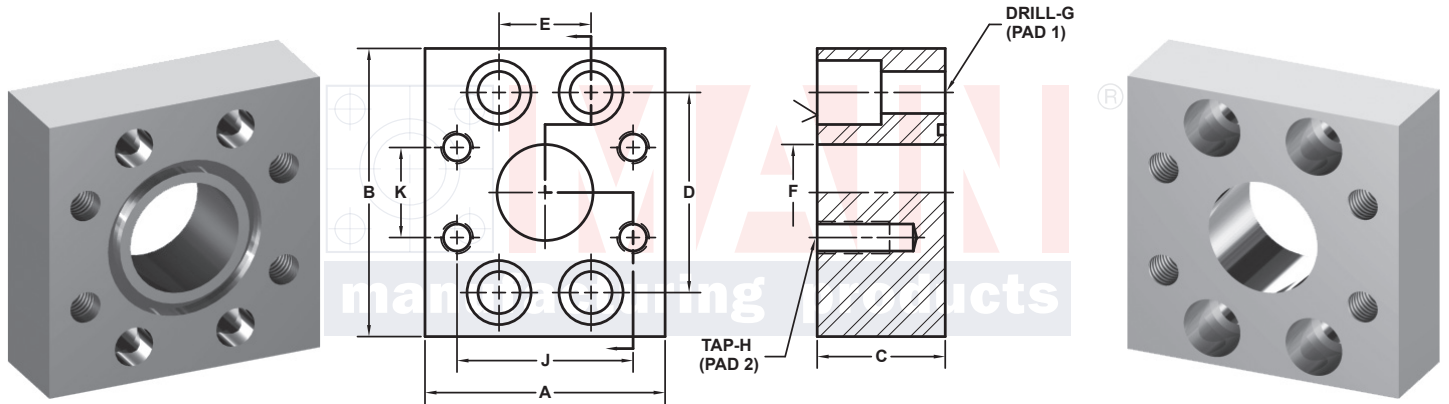

3181 TRI-PARK DR. GRAND BLANC, MI 48439 800-521-7918 810-953-1380 FAX 810-953-1385 INFO@MAINMFG.COM

SAE BOLT PATTERN

62 SERIES TO 61 SERIES^⑤

PAD 1 C62	PAD 2 C61	PART NUMBER	A	B	C	D	E	F	G	H	J	K	MOUNTING KIT ^①		
													PART NO.	BOLT SIZE	O-RING
2	2	1339-32-32	4.00	5.25	1.75	3.812	1.750	1.94	.78	1/2-13	3.062	1.688	MK 563	3/4-10 x 2	228
2	1½	1339-32-24	4.00	5.25	2.00	3.812	1.750	1.50	.78	1/2-13	2.750	1.406	MK 1574	3/4-10 x 2 1/4	228
2	1¼	1339-32-20	4.00	5.25	2.00	3.812	1.750	1.25	.78	7/16-14	2.312	1.188	MK 1574	3/4-10 x 2 1/4	228
2	1	1339-32-16	4.00	5.25	1.75	3.812	1.750	1.00	.78	3/8-16	2.062	1.031	MK 563	3/4-10 x 2	228
2	¾	1339-32-12	4.00	5.25	1.75	3.812	1.750	.75	.78	3/8-16	1.875	.875	MK 563	3/4-10 x 2	228
2	½	1339-32-08	4.00	5.25	1.75	3.812	1.750	.50	.78	5/16-18	1.500	.688	MK 563	3/4-10 x 2	228
2½ ^④	2½ ^②	1339-40-40	5.00	6.88	2.00	4.875	2.312	2.44	.94	1/2-13	3.500	2.000	MK 1513	7/8-9 x 2 1/4	232
2½ ^④	2	1339-40-32	5.00	6.88	2.00	4.875	2.312	1.94	.94	1/2-13	3.062	1.688	MK 1513	7/8-9 x 2 1/4	232
2½ ^④	1½	1339-40-24	5.00	6.88	2.00	4.875	2.312	1.50	.94	1/2-13	2.750	1.406	MK 1513	7/8-9 x 2 1/4	232
2½ ^④	1¼	1339-40-20	5.00	6.88	2.00	4.875	2.312	1.25	.94	7/16-14	2.312	1.188	MK 1513	7/8-9 x 2 1/4	232
2½ ^④	1	1339-40-16	5.00	6.88	2.00	4.875	2.312	1.00	.94	3/8-16	2.062	1.031	MK 1513	7/8-9 x 2 1/4	232
2½ ^④	¾	1339-40-12	5.00	6.88	2.00	4.875	2.312	.75	.94	3/8-16	1.875	.875	MK 1513	7/8-9 x 2 1/4	232
2½ ^④	½	1339-40-08	5.00	6.88	2.00	4.875	2.312	.50	.94	5/16-18	1.500	.688	MK 1513	7/8-9 x 2 1/4	232
3 ^④	3 ^③	1339-48-48	6.00	8.50	2.50	6.000	2.812	2.94	1.19	5/8-11	4.188	2.438	MK 1514	1 1/8-7 x 2 1/2	237
3 ^④	2½ ^②	1339-48-40	6.00	8.50	2.50	6.000	2.812	2.44	1.19	1/2-13	3.500	2.000	MK 718	1 1/8-7 x 4 1/2	237
3 ^④	2	1339-48-32	6.00	8.50	2.50	6.000	2.812	1.94	1.19	1/2-13	3.062	1.688	MK 718	1 1/8-7 x 4 1/2	237
3 ^④	1½	1339-48-24	6.00	8.50	2.50	6.000	2.812	1.50	1.19	1/2-13	2.750	1.406	MK 718	1 1/8-7 x 4 1/2	237
3 ^④	1¼	1339-48-20	6.00	8.50	2.50	6.000	2.812	1.25	1.19	7/16-14	2.312	1.188	MK 718	1 1/8-7 x 4 1/2	237
3 ^④	1	1339-48-16	6.00	8.50	2.50	6.000	2.812	1.00	1.19	3/8-16	2.062	1.031	MK 718	1 1/8-7 x 4 1/2	237

① Order Separately ② 2500 PSI Max ③ 2000 PSI Max ④ Not included in SAE J518 specifications

⑤ **CAUTION:** Flange adapter pressure rating cannot exceed 61 series pad connection.

FLANGE ADAPTERS

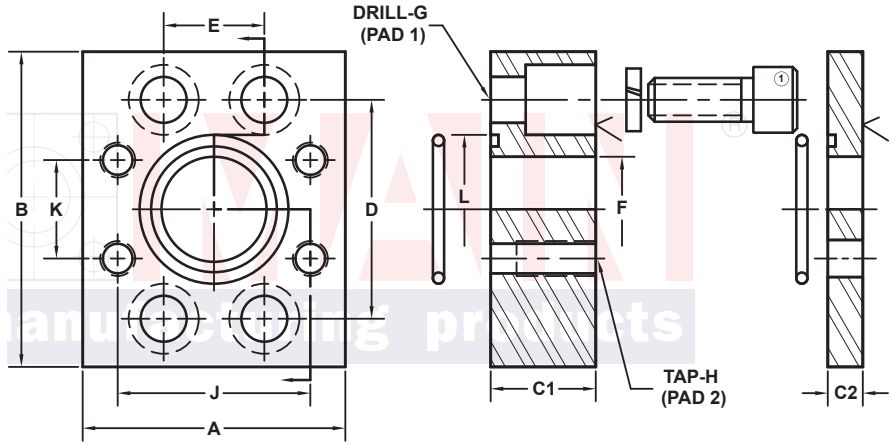

3181 TRI-PARK DR. GRAND BLANC, MI 48439 800-521-7918 810-953-1380 FAX 810-953-1385 INFO@MAINMFG.COM

SAE BOLT PATTERN															62 SERIES TO 61 SERIES ^⑤		
PAD 1 C62	PAD 2 C61	PART NUMBER	A	B	C1	C2	D	E	F	G	H	J	K	L	MOUNTING KIT ^①		
															BOLT SIZE	O-RINGS	
3/4	1	1339-12-16	2.81	3.00	1.00	.38	2.000	.937	.75	.41	3/8-16	2.062	1.031	1.250	3/8-16 x 1	214	
1	1 1/4	1339-16-20	3.25	3.25	1.25	.38	2.250	1.093	1.00	.47	7/16-14	2.312	1.188	1.562	7/16-14 x 1 1/4	219	
1	1 1/2	1339-16-24	3.75	3.25	1.25	.38	2.250	1.093	1.00	.47	1/2-13	2.750	1.406	1.562	7/16-14 x 1 1/4	219	
1 1/4	1 1/2	1339-20-24	3.75	3.75	1.25	.38	2.625	1.250	1.25	.53	1/2-13	2.750	1.406	1.750	1/2-13 x 1 1/4	222	
1 1/4	2	1339-20-32	4.00	3.75	1.25	.38	2.625	1.250	1.25	.53	1/2-13	3.062	1.688	1.750	1/2-13 x 1 1/4	222	
1 1/2	2	1339-24-32	4.00	4.50	1.50	.50	3.125	1.437	1.50	.66	1/2-13	3.062	1.688	2.125	5/8-11 x 1 1/2	225	
2	2 1/2^②	1339-32-40	4.50	5.25	1.75	.50	3.812	1.750	1.94	.78	1/2-13	3.500	2.000	2.500	3/4-10 x 2	228	

① Included: (4) Bolts, (4) Lock Washers, (2) O-Rings ② 2500 PSI Max

⑤ **CAUTION:** Flange adapter pressure rating cannot exceed 61 series pad connection.