

FLANGE ADAPTERS

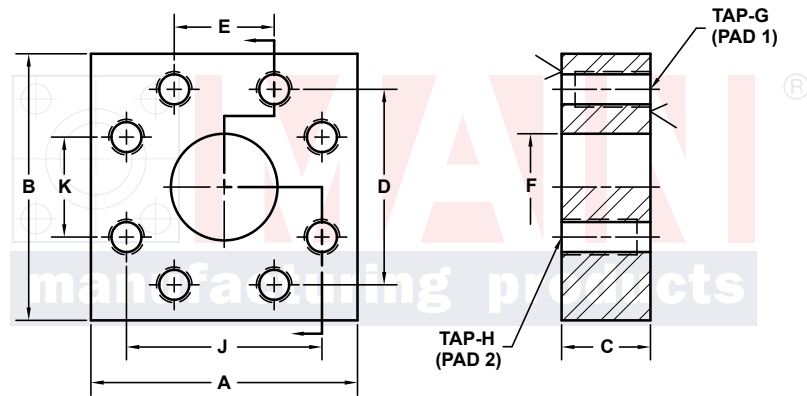
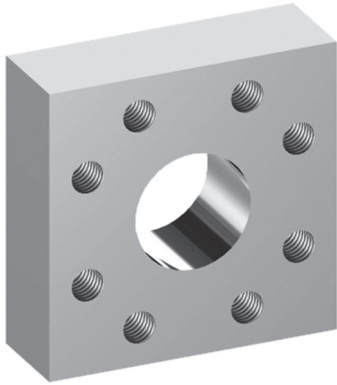

3181 TRI-PARK DR. GRAND BLANC, MI 48439 800-521-7918 810-953-1380 FAX 810-953-1385 INFO@MAINMFG.COM

SAE BOLT PATTERN				62 SERIES TO 62 SERIES									
PAD 1 C62	PAD 2 C62	PART NUMBER	A	B	C	D	E	F	G	H	J	K	
1/2	1/2	1342-08-08	2.25	2.25	1.00	1.594	.718	.50	5/16-18	5/16-18	1.594	.718	
3/4	3/4	1342-12-12	3.00	3.00	1.00	2.000	.937	.75	3/8-16	3/8-16	2.000	.937	
3/4	1/2	1342-12-08	2.25	2.81	1.50	2.000	.937	.50	3/8-16	5/16-18	1.594	.718	
1	1	1342-16-16	3.25	3.25	1.25	2.250	1.093	1.00	7/16-14	7/16-14	2.250	1.093	
1	3/4	1342-16-12	3.00	3.19	1.75	2.250	1.093	.75	7/16-14	3/8-16	2.000	.937	
1	1/2	1342-16-08	2.25	3.19	1.50	2.250	1.093	.50	7/16-14	5/16-18	1.594	.718	
1 1/4	1 1/4	1342-20-20	3.75	3.75	1.25	2.625	1.250	1.25	1/2-13	1/2-13	2.625	1.250	
1 1/4	1	1342-20-16	3.25	3.75	1.75	2.625	1.250	1.00	1/2-13	7/16-14	2.250	1.093	
1 1/4	3/4	1342-20-12	2.81	3.75	1.75	2.625	1.250	.75	1/2-13	3/8-16	2.000	.937	
1 1/4	1/2	1342-20-08	2.75	3.75	1.50	2.625	1.250	.50	1/2-13	5/16-18	1.594	.718	
1 1/2	1 1/2	1342-24-24	4.50	4.50	1.75	3.125	1.437	1.50	5/8-11	5/8-11	3.125	1.437	
1 1/2	1 1/4	1342-24-20	3.75	4.50	2.00	3.125	1.437	1.25	5/8-11	1/2-13	2.625	1.250	
1 1/2	1	1342-24-16	3.25	4.50	2.00	3.125	1.437	1.00	5/8-11	7/16-14	2.250	1.093	
1 1/2	3/4	1342-24-12	3.25	4.50	1.75	3.125	1.437	.75	5/8-11	3/8-16	2.000	.937	
1 1/2	1/2	1342-24-08	3.25	4.50	1.50	3.125	1.437	.50	5/8-11	5/16-18	1.594	.718	

FLANGE ADAPTERS

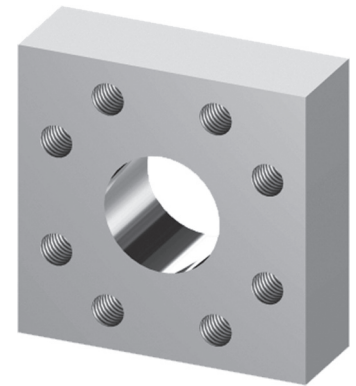
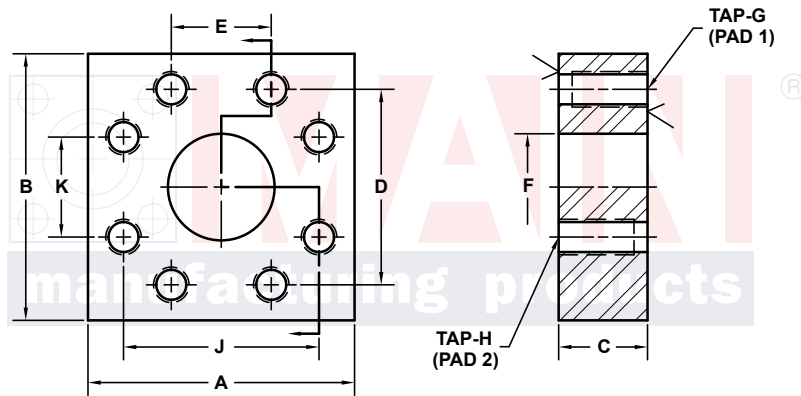

3181 TRI-PARK DR. GRAND BLANC, MI 48439 800-521-7918 810-953-1380 FAX 810-953-1385 INFO@MAINMFG.COM

SAE BOLT PATTERN			62 SERIES TO 62 SERIES										
PAD 1 C62	PAD 2 C62	PART NUMBER	A	B	C	D	E	F	G	H	J	K	
2	2	1342-32-32	5.25	5.25	1.75	3.812	1.750	1.94	3/4-10	3/4-10	3.812	1.750	
2	1½	1342-32-24	4.50	5.25	2.25	3.812	1.750	1.50	3/4-10	5/8-11	3.125	1.437	
2	1¼	1342-32-20	4.00	5.25	2.00	3.812	1.750	1.25	3/4-10	1/2-13	2.625	1.250	
2	1	1342-32-16	4.00	5.25	1.75	3.812	1.750	1.00	3/4-10	7/16-14	2.250	1.093	
2	¾	1342-32-12	4.00	5.25	1.75	3.812	1.750	.75	3/4-10	3/8-16	2.000	.937	
2	½	1342-32-08	4.00	5.25	1.75	3.812	1.750	.50	3/4-10	5/16-18	1.594	.718	
2½^①	2½^①	1342-40-40	6.88	7.00	2.00	4.875	2.312	2.44	7/8-9	7/8-9	4.875	2.312	
2½^①	2	1342-40-32	5.25	7.00	2.50	4.875	2.312	1.94	7/8-9	3/4-10	3.812	1.750	
2½^①	1½	1342-40-24	5.00	7.00	2.50	4.875	2.312	1.50	7/8-9	5/8-11	3.125	1.437	
2½^①	1¼	1342-40-20	5.00	6.88	2.00	4.875	2.312	1.25	7/8-9	1/2-13	2.625	1.250	
2½^①	1	1342-40-16	5.00	6.88	2.00	4.875	2.312	1.00	7/8-9	7/16-14	2.250	1.093	
2½^①	¾	1342-40-12	5.00	6.88	2.00	4.875	2.312	.75	7/8-9	3/8-16	2.000	.937	
2½^①	½	1342-40-08	5.00	6.88	2.00	4.875	2.312	.50	7/8-9	5/16-18	1.594	.718	
3^①	3^①	1342-48-48	8.50	8.50	2.50	6.000	2.812	2.94	1 1/8-7	1 1/8-7	6.000	2.812	
3^①	2½^①	1342-48-40	7.00	8.50	2.50	6.000	2.812	2.44	1 1/8-7	7/8-9	4.875	2.312	
3^①	2	1342-48-32	6.00	8.50	2.50	6.000	2.812	1.94	1 1/8-7	3/4-10	3.812	1.750	
3^①	1½	1342-48-24	6.00	8.50	2.50	6.000	2.812	1.50	1 1/8-7	5/8-11	3.125	1.437	
3^①	1¼	1342-48-20	6.00	8.50	2.50	6.000	2.812	1.25	1 1/8-7	1/2-13	2.625	1.250	
3^①	1	1342-48-16	6.00	8.50	2.50	6.000	2.812	1.00	1 1/8-7	7/16-14	2.250	1.093	

① Not included in SAE J518 specifications