

SOCKET WELD PIPE IN-LINE FLANGES (Pg 1/3)

SAE J518 61 SERIES / ISO6162-1 PATTERN

FLANGE SIZE	PIPE SIZE	PART NUMBER	A	B	C	D	E	F	Gmm	H	K	MOUNTING KIT [Ⓢ]			WT
									Jmm			PART NO.	SCREW SIZE	O-RING	
1/2	1/2	1101-08-08M8	1.50	2.12	.75	1.500	.688	.50	8.5	.38	.860	MKM 501	M8 x 30	210	.5
		M8x1.25							-----			-----	---		
1/2	3/4	1102-08-12M8	1.75	2.12	1.75	1.500	.688	.50	M8x1.25	.50	1.070	-----	-----	---	1.6
		-----							-----			---			
3/4	1/2	1101-12-08M10	1.75	2.62	1.00	1.875	.875	.50	10.5	.38	.860	MKM 502	M10 x 40	214	1.1
		M10x1.5							-----			-----	---		
3/4	3/4	1101-12-12M10	1.75	2.62	1.00	1.875	.875	.75	10.5	.50	1.070	MKM 502	M10 x 40	214	1.0
		M10x1.5							-----			-----	---		
3/4	1	-----	2.00	2.62	1.75	1.875	.875	.75	---	.50	1.335	-----	-----	---	2.1
		1102-12-16M10							M10x1.5			-----	---		
1	1/2	1101-16-08M10	2.00	2.82	1.00	2.062	1.031	.50	10.5	.38	.860	MKM 503	M10 x 40	219	1.4
		M10x1.5							-----			-----	---		
1	3/4	1101-16-12M10	2.00	2.82	1.00	2.062	1.031	.75	10.5	.50	1.070	MKM 503	M10 x 40	219	1.3
		M10x1.5							-----			-----	---		
1	1	1101-16-16M10	2.00	2.82	1.00	2.062	1.031	1.00	10.5	.50	1.335	MKM 503	M10 x 40	219	1.2
		M10x1.5							-----			-----	---		
1	1 1/4	-----	2.50	2.82	2.00	2.062	1.031	1.00	---	.50	1.680	-----	-----	---	3.2
		1102-16-20M10							M10x1.5			-----	---		
1 1/4	3/4	1101-20-12M10+	2.50	3.19	1.00	2.312	1.188	.75	10.5	.50	1.070	MKM 3524	M10 x 40	222	1.8
		M10x1.5							-----			-----	---		
1 1/4	1	1101-20-16M10+	2.50	3.19	1.00	2.312	1.188	1.00	10.5	.50	1.335	MKM 3524	M10 x 40	222	1.6
		M10x1.5							-----			-----	---		

MATERIAL:
Low Carbon Steel

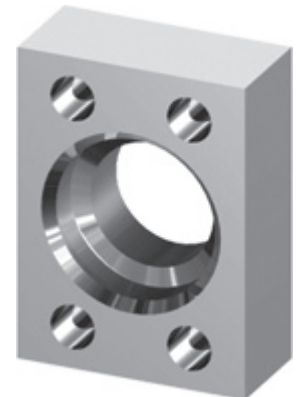
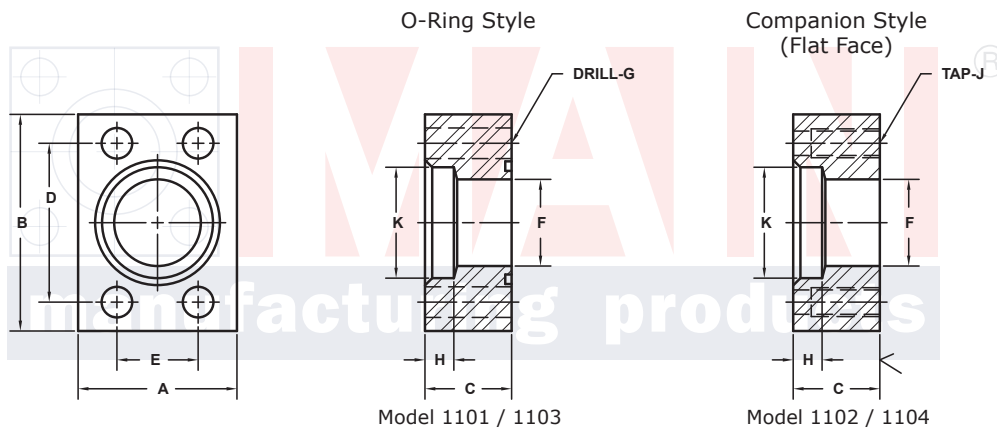

3181 TRI-PARK DR. GRAND BLANC, MI 48439 800-521-7918 810-953-1380 FAX 810-953-1385 INFO@MAINMFG.COM

SAE J518 62 SERIES / ISO6162-2 PATTERN

FLANGE SIZE	PIPE SIZE	PART NUMBER	A	B	C	D	E	F	Gmm	H	K	MOUNTING KIT [Ⓢ]			WT
									Jmm			PART NO.	SCREW SIZE	O-RING	
1/2	1/2	1103-08-08M8	1.75	2.22	1.00	1.594	.718	.50	8.5	.50	.860	MKM 512	M8 x 35	210	.8
		M8x1.25							-----			-----	---		
1/2	3/4	1104-08-12M8	1.75	2.22	1.75	1.594	.718	.50	M8x1.25	.50	1.070	-----	-----	---	1.6
		-----							-----			---			
3/4	1/2	1103-12-08M10	2.00	2.81	1.00	2.000	.937	.50	10.5	.50	.860	MKM 502	M10 x 40	214	1.4
		M10x1.5							-----			-----	---		
3/4	3/4	1103-12-12M10	2.00	2.81	1.00	2.000	.937	.75	10.5	.50	1.070	MKM 502	M10 x 40	214	1.3
		M10x1.5							-----			-----	---		
3/4	1	-----	2.25	2.81	1.00	2.000	.937	.75	---	.50	1.335	-----	-----	---	1.2
		1104-12-16M10							M10x1.5			-----	---		
1	3/4	1103-16-12M12	2.25	3.19	1.00	2.250	1.093	.75	12.5	.50	1.070	MKM 513	M12 x 45	219	1.7
		M12x1.75							-----			-----	---		
1	1	1103-16-16M12	2.25	3.19	1.00	2.250	1.093	1.00	12.5	.50	1.335	MKM 513	M12 x 45	219	1.5
		M12x1.75							-----			-----	---		
1	1 1/4	-----	2.50	3.19	2.50	2.250	1.093	1.00	---	.50	1.680	-----	-----	---	4.6
		1104-16-20M12							M12x1.75			-----	---		

Ⓢ Order Separately

NOTE: DIMENSIONS ARE IN INCHES UNLESS OTHERWISE NOTED. + Also Available for M12 Bolts

© Copyright MAIN Mfg. 2017

SOCKET WELD PIPE IN-LINE FLANGES (Pg 2/3)

SAE J518 61 SERIES / ISO6162-1 PATTERN

FLANGE SIZE	PIPE SIZE	PART NUMBER	A	B	C	D	E	F	Gmm	H	K	MOUNTING KIT®			WT
									Jmm			PART NO.	SCREW SIZE	O-RING	
1 1/4	1 1/4	1101-20-20M10†	2.50	3.19	1.00	2.312	1.188	1.25	10.5	.50	1.680	MKM 3524	M10 x 40	222	1.5
		M10x1.5							-----			-----	---		
1 1/4	1 1/2	1102-20-20M10†	3.00	3.19	2.50	2.312	1.188	1.25	---	.50	1.920	-----	-----	---	5.4
		M10x1.5							-----			-----	---		
1 1/2	3/4	1101-24-12M12‡	2.75	3.75	1.25	2.750	1.406	.75	13.0	.50	1.070	MKM 3596	M12 x 50	225	3.2
		M12x1.75							-----			-----	---		
1 1/2	1	1101-24-16M12‡	2.75	3.75	1.25	2.750	1.406	1.00	13.0	.50	1.335	MKM 3596	M12 x 50	225	3.0
		M12x1.75							-----			-----	---		
1 1/2	1 1/4	1101-24-20M12‡	2.75	3.75	1.25	2.750	1.406	1.25	13.0	.50	1.680	MKM 3596	M12 x 50	225	2.8
		M12x1.75							-----			-----	---		
1 1/2	1 1/2	1101-24-24M12‡	2.75	3.75	1.25	2.750	1.406	1.50	13.0	.50	1.920	MKM 3596	M12 x 50	225	2.5
		M12x1.75							-----			-----	---		
1 1/2	2	1102-24-24M12‡	3.50	3.75	2.25	2.750	1.406	1.50	---	.50	2.411	-----	-----	---	3.2
		M12x1.75							-----			-----	---		
2	1 1/4	1101-32-20M12‡	3.25	4.00	1.50	3.062	1.688	1.25	13.0	.50	1.680	MKM 3501	M12 x 55	228	4.5
		M12x1.75							-----			-----	---		
2	1 1/2	1101-32-24M12‡	3.25	4.00	1.50	3.062	1.688	1.50	13.0	.50	1.920	MKM 3501	M12 x 55	228	4.3
		M12x1.75							-----			-----	---		
2	2	1101-32-32M12‡	3.25	4.00	1.50	3.062	1.688	1.94	13.0	.62	2.411	MKM 3501	M12 x 55	228	3.6
		M12x1.75							-----			-----	---		
2	2 1/2	1102-32-32M12‡	4.00	4.00	2.50	3.062	1.688	1.94	---	.50	2.911	-----	-----	---	8.3
		M12x1.75							-----			-----	---		

MATERIAL:
Low Carbon Steel

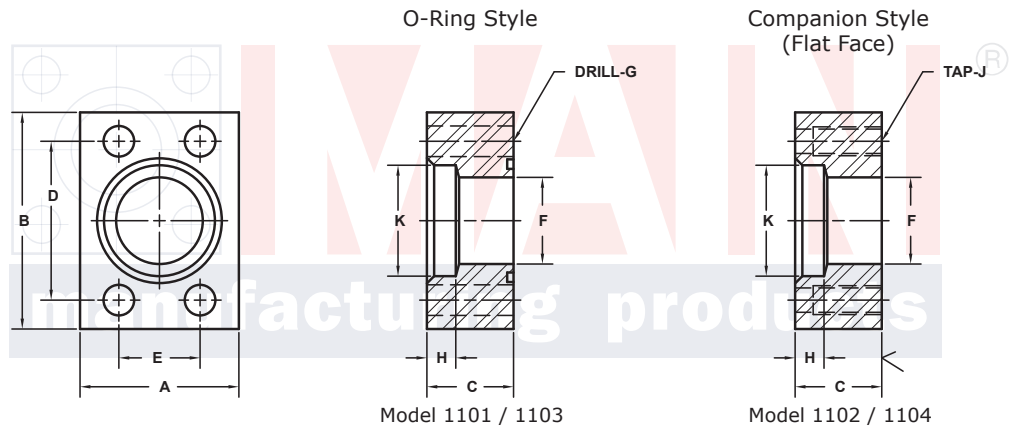
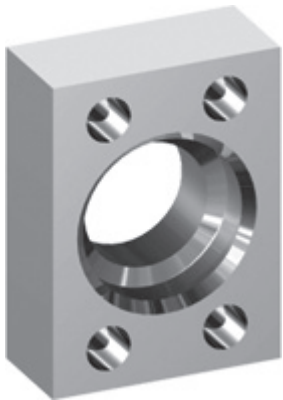

3181 TRI-PARK DR. GRAND BLANC, MI 48439 800-521-7918 810-953-1380 FAX 810-953-1385 INFO@MAINMFG.COM

SAE J518 62 SERIES / ISO6162-2 PATTERN

FLANGE SIZE	PIPE SIZE	PART NUMBER	A	B	C	D	E	F	Gmm	H	K	MOUNTING KIT®			WT
									Jmm			PART NO.	SCREW SIZE	O-RING	
1 1/4	3/4	1103-20-12M12‡	2.75	3.75	1.25	2.625	1.250	.75	13.0	.50	1.070	MKM 1502	M12 x 50	222	3.0
		M12x1.75							-----			-----	---		
1 1/4	1	1103-20-16M12‡	2.75	3.75	1.25	2.625	1.250	1.00	13.0	.50	1.335	MKM 1502	M12 x 50	222	2.9
		M12x1.75							-----			-----	---		
1 1/4	1 1/4	1103-20-20M12‡	2.75	3.75	1.25	2.625	1.250	1.25	13.0	.50	1.680	MKM 1502	M12 x 50	222	2.7
		M12x1.75							-----			-----	---		
1 1/4	1 1/2	1104-20-24M12‡	3.00	3.75	2.00	2.625	1.250	1.25	---	.50	1.920	-----	-----	---	5.1
		M12x1.75							-----			-----	---		
1 1/2	1	1103-24-16M16	3.25	4.50	1.50	3.125	1.437	1.00	17.0	.50	1.335	MKM 515	M16 x 60	225	5.3
		M16x2							-----			-----	---		
1 1/2	1 1/4	1103-24-20M16	3.25	4.50	1.50	3.125	1.437	1.25	17.0	.50	1.680	MKM 515	M16 x 60	225	5.1
		M16x2							-----			-----	---		
1 1/2	1 1/2	1103-24-24M16	3.25	4.50	1.50	3.125	1.437	1.50	17.0	.50	1.920	MKM 515	M16 x 60	225	4.8
		M16x2							-----			-----	---		
1 1/2	2	1104-24-24M16	4.00	4.50	3.00	3.125	1.437	1.50	---	.62	2.411	-----	-----	---	12.6
		M16x2							-----			-----	---		

① Order Separately

SOCKET WELD PIPE IN-LINE FLANGES (Pg 3/3)

SAE J518 61 SERIES / ISO6162-1 PATTERN

FLANGE SIZE	PIPE SIZE	PART NUMBER	A	B	C	D	E	F	Gmm Jmm	H	K	MOUNTING KIT ^①			WT
												PART NO.	SCREW SIZE	O-RING	
2½ ^②	2	1101-40-32M12‡	4.00	4.50	1.75	3.500	2.000	1.94	13.0	.62	2.411	MKM 4511	M12 x 60	232	6.8
		1102-40-32M12‡							M12x1.75			-----	---		
2½ ^②	2½	1101-40-40M12‡	4.00	4.50	1.75	3.500	2.000	2.44	13.0	.75	2.911	MKM 4511	M12 x 60	232	5.7
		1102-40-40M12‡							M12x1.75			-----	---		
2½ ^②	3	-----	5.00	5.00	3.00	3.500	2.000	2.44	-----	.75	3.540	-----	-----	---	15.6
		1102-40-48M12‡							M12x1.75			-----	---		
3 ^③	2½	1101-48-40M16	4.50	5.31	2.00	4.188	2.438	2.44	17.0	.75	2.911	MKM 508	M16 x 75	237	9.7
		1102-48-40M16							M16x2			-----	---		
3 ^③	3	1101-48-48M16	4.50	5.31	2.00	4.188	2.438	2.94	17.0	.75	3.540	MKM 508	M16 x 75	237	8.3
		1102-48-48M16							M16x2			-----	---		
3½ ^④	3	1101-56-48M16	5.00	6.00	1.50	4.750	2.750	2.94	17.0	.75	3.540	MKM 509	M16 x 65	241	8.5
		1102-56-48M16							M16x2			-----	---		
3½ ^④	3½	1101-56-56M16	5.00	6.00	1.50	4.750	2.750	3.44	17.0	.75	4.045	MKM 509	M16 x 65	241	7.5
		1102-56-56M16							M16x2			-----	---		
4 ^④	3½	1101-64-56M16	5.50	6.38	1.50	5.125	3.062	3.44	17.0	.75	4.045	MKM 510	M16 x 60	245	9.3
		1102-64-56M16							M16x2			-----	---		
4 ^④	4	1101-64-64M16	5.50	6.38	1.50	5.125	3.062	3.94	17.0	.75	4.550	MKM 510	M16 x 60	245	8.3
		1102-64-64M16							M16x2			-----	---		
5 ^④	4	1101-80-64M16	7.00	7.25	2.00	6.000	3.625	3.94	17.0	.75	4.550	MKM 511	M16 x 75	253	19.7
		1102-80-64M16							M16x2			-----	---		
5 ^④	5	1101-80-80M16	7.00	7.25	2.00	6.000	3.625	4.94	17.0	.75	5.635	MKM 511	M16 x 75	253	16.0
		1102-80-80M16							M16x2			-----	---		

MATERIAL:
Low Carbon Steel

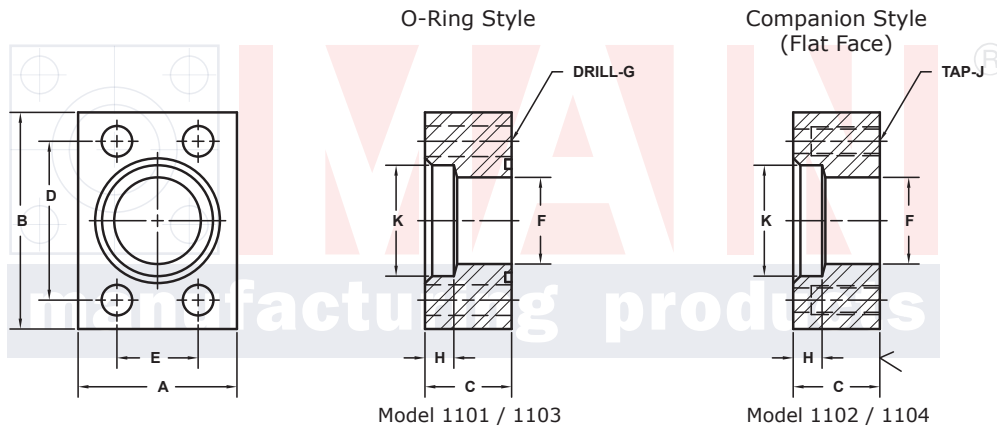

Model 1101 / 1103

Model 1102 / 1104

3181 TRI-PARK DR. GRAND BLANC, MI 48439 800-521-7918 810-953-1380 FAX 810-953-1385 INFO@MAINMFG.COM

SAE J518 62 SERIES / ISO6162-2 PATTERN

FLANGE SIZE	PIPE SIZE	PART NUMBER	A	B	C	D	E	F	Gmm Jmm	H	K	MOUNTING KIT ^①			WT
												PART NO.	SCREW SIZE	O-RING	
2	1½	1103-32-24M20	4.00	5.25	1.75	3.812	1.750	1.50	21.0	.50	1.920	MKM 516	M20 x 70	228	8.5
		1104-32-24M20							M20x2.5			-----	---		
2	2	1103-32-32M20	4.00	5.25	1.75	3.812	1.750	1.94	21.0	.62	2.411	MKM 516	M20 x 70	228	7.8
		1104-32-32M20							M20x2.5			-----	---		
2	2½	-----	5.00	5.50	3.00	3.812	1.750	1.94	-----	.62	2.911	-----	-----	---	19.1
		1104-32-40M20							M20x2.5			-----	---		
2½	2	1103-40-32M24	5.00	6.88	2.00	4.875	2.312	1.94	25.5	.62	2.411	MKM 517	M24 x 80	232	15.7
		1104-40-32M24							M24x3			-----	---		
2½	2½	1103-40-40M24	5.00	6.88	2.00	4.875	2.312	2.44	25.5	.62	2.911	MKM 517	M24 x 80	232	15.2
		1104-40-40M24							M24x3			-----	---		
2½	3	-----	5.00	6.88	2.00	4.875	2.312	2.44	-----	.62	3.540	-----	-----	---	14.6
		1104-40-48M24							M24x3			-----	---		
3	2½	1103-48-40M30	6.00	8.50	2.50	6.000	2.812	2.44	32.0	.62	2.911	MKM 518	M30 x 110	237	28.8
		1104-48-40M30							M30x3.5			-----	---		
3	3	1103-48-48M30	6.00	8.50	2.50	6.000	2.812	2.94	32.0	.62	3.540	MKM 518	M30 x 110	237	28.0
		1104-48-48M30							M30x3.5			-----	---		

① Order Separately ② 2500 PSI Max ③ 2000 PSI Max ④ 500 PSI Max

NOTE: DIMENSIONS ARE IN INCHES UNLESS OTHERWISE NOTED.

‡ Also Available for M14 Bolts

© Copyright MAIN Mfg. 2017