

DOUBLE O-RING ADAPTERS

SAE BOLT PATTERN						61 SERIES						
FLANGE SIZE	PIPE SIZE	PART NUMBER	A	B	C	D	E	F	G	L	O-RING ^①	WT
1/2	NA	1275-08-08	1.50	2.12	.50	1.500	.688	.50	.34	1.000	210	.3
3/4	NA	1275-12-12	1.75	2.62	.50	1.875	.875	.75	.41	1.250	214	.5
1	NA	1275-16-16	2.00	2.82	.50	2.062	1.031	1.00	.41	1.562	219	.6
1 1/4	NA	1275-20-20	2.50	3.19	.50	2.312	1.188	1.25	.47	1.750	222	.8
1 1/2	NA	1275-24-24	2.75	3.75	.50	2.750	1.406	1.50	.53	2.125	225	1.0
2	NA	1275-32-32	3.25	4.00	.50	3.062	1.688	1.94	.53	2.500	228	1.2
2 1/2	NA	1275-40-40	4.00	4.50	.50	3.500	2.000	2.44	.53	3.000	232	1.7
3	NA	1275-48-48	4.50	5.31	.50	4.188	2.438	2.94	.66	3.625	237	2.1

MATERIAL:
Low Carbon Steel

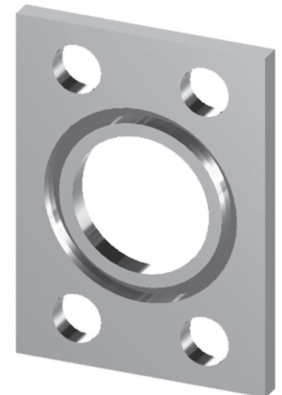
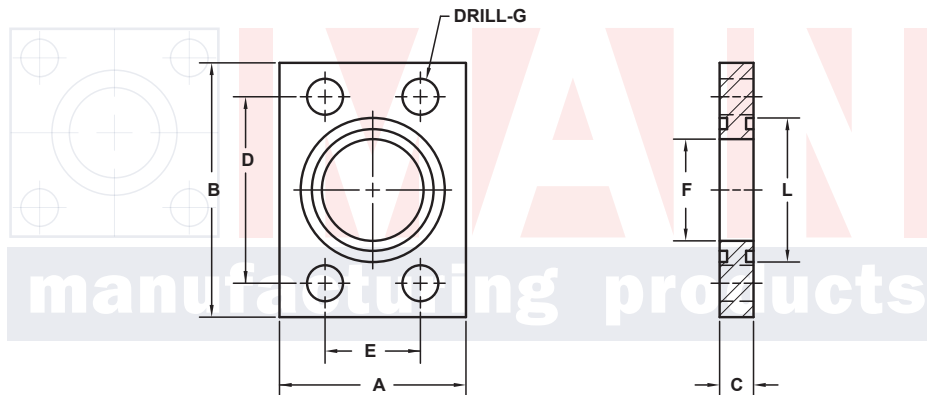

3181 TRI-PARK DR. GRAND BLANC, MI 48439 800-521-7918 810-953-1380 FAX 810-953-1385 INFO@MAINMFG.COM

SAE BOLT PATTERN						62 SERIES						
FLANGE SIZE	PIPE SIZE	PART NUMBER	A	B	C	D	E	F	G	L	O-RING ^①	WT
1/2	NA	1276-08-08	1.75	2.22	.50	1.594	.718	.50	.34	1.000	210	.4
3/4	NA	1276-12-12	2.00	2.81	.50	2.000	.937	.75	.41	1.250	214	.6
1	NA	1276-16-16	2.25	3.19	.50	2.250	1.093	1.00	.47	1.562	219	.8
1 1/4	NA	1276-20-20	2.75	3.75	.50	2.625	1.250	1.25	.53	1.750	222	1.1
1 1/2	NA	1276-24-24	3.25	4.50	.50	3.125	1.437	1.50	.66	2.125	225	1.6
2	NA	1276-32-32	4.00	5.25	.50	3.812	1.750	1.94	.78	2.500	228	2.2

① Includes 2 Buna-N O-Rings