

# FLANGED CLAMPS

With Tapped Bolt Holes

SAE BOLT PATTERN								61 SERIES				
FLANGE SIZE	PART NUMBER	A	B	C	D	E	F	G	H	J	K	WT
1/2	1222-08-08	1.81	2.12	.75	1.500	.688	.955	5/16 - 18	.245	.50	1.219	.3
3/4	1222-12-12	2.05	2.56	.88	1.875	.875	1.265	3/8 - 16	.245	.56	1.531	.4
1	1222-16-16	2.31	2.75	.94	2.062	1.031	1.515	3/8 - 16	.295	.62	1.781	.5
1 1/4	1222-20-20	2.88	3.12	.88	2.312	1.188	1.720	7/16 - 14	.295	.56	2.031	.8
1 1/2	1222-24-24	3.25	3.69	1.00	2.750	1.406	2.000	1/2 - 13	.295	.62	2.406	.9
2	1222-32-32	3.81	4.00	1.03	3.062	1.688	2.470	1/2 - 13	.355	.62	2.844	1.2
2 1/2 <sup>①</sup>	1222-40-40	4.28	4.50	1.50	3.500	2.000	2.950	1/2 - 13	.355	.75	3.344	1.9
3 <sup>②</sup>	1222-48-48	5.16	5.31	1.62	4.188	2.438	3.580	5/8 - 11	.355	.88	4.031	2.9
3 1/2 <sup>③</sup>	1222-56-56	5.50	6.00	1.12	4.750	2.750	4.030	5/8 - 11	.422	.88	4.531	3.4
4 <sup>③</sup>	1222-64-64	6.00	6.38	1.38	5.125	3.062	4.530	5/8 - 11	.422	1.00	5.031	3.9

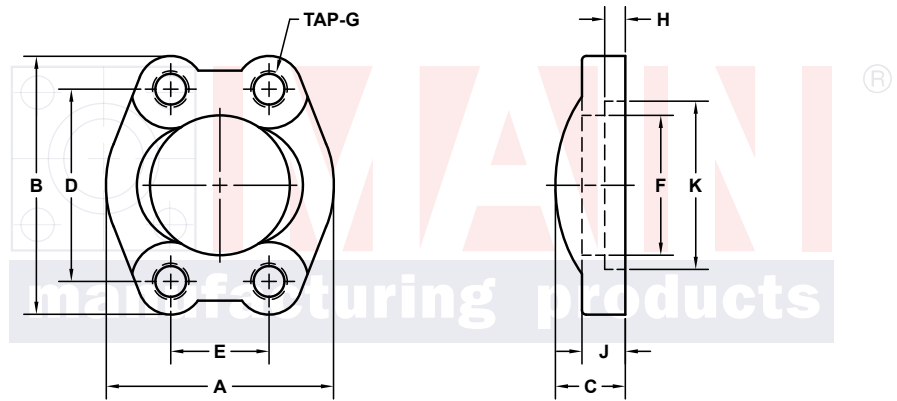
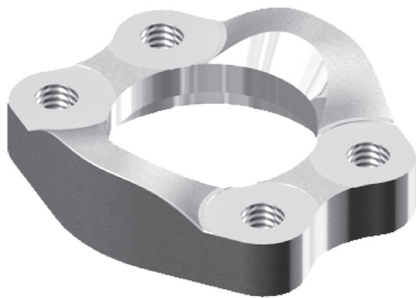

3181 TRI-PARK DR. GRAND BLANC, MI 48439 800-521-7918 810-953-1380 FAX 810-953-1385 INFO@MAINMFG.COM

SAE BOLT PATTERN								62 SERIES				
FLANGE SIZE	PART NUMBER	A	B	C	D	E	F	G	H	J	K	WT
1/2	1224-08-08	1.88	2.22	.88	1.594	.718	.970	5/16 - 18	1.000	.62	1.281	.4
3/4	1224-12-12	2.38	2.81	1.12	2.000	.937	1.280	3/8 - 16	1.250	.75	1.656	.8
1	1224-16-16	2.75	3.19	1.31	2.250	1.093	1.530	7/16 - 14	1.562	.94	1.906	1.2
1 1/4	1224-20-20	3.06	3.75	1.50	2.625	1.250	1.750	1/2 - 13	1.750	1.06	2.156	1.8
1 1/2	1224-24-24	3.75	4.44	1.69	3.125	1.437	2.030	5/8 - 11	2.125	1.19	2.531	3.0
2	1224-32-32	4.50	5.25	2.06	3.812	1.750	2.660	3/4 - 10	2.500	1.44	3.156	4.7

① 2500 PSI Max ② 2000 PSI Max ③ 500 PSI Max