

BUTT WELD IN-LINE FLANGES

For Schedule 160 Pipe ⑥

3000 SERIES SQUARE BOLT PATTERN

FLANGE SIZE	PIPE SIZE	PART NUMBER	A	B	C	D	E	F	G	H	K	MOUNTING KIT®			WT
									J			PART NO.	SCREW SIZE	O-RING	
3/4	3/4	1403-12-12	2.25	1.12	1.25	.719	1.438	.61	.41	.38	1.12	MK 528	3/8-16 x 1 3/4	216	1.1
		1404-12-12							3/8-16			---	---		
1	1	1403-16-16	3.00	1.50	1.25	1.000	2.000	.81	.53	.38	1.38	MK 529	1/2-13 x 1 3/4	222	1.6
		1404-16-16							1/2-13			---	---		
1 1/4	1 1/4	1403-20-20	3.00	1.50	1.25	1.000	2.000	1.16	.53	.38	1.75	MK 529	1/2-13 x 1 3/4	222	1.5
		1404-20-20							1/2-13			---	---		
1 1/2	1 1/2	1403-24-24	4.00	2.00	1.50	1.375	2.750	1.34	.66	.50	2.00	MK 581	5/8-11 x 2	228	3.3
		1404-24-24							5/8-11			---	---		
2	2	1403-32-32	4.00	2.00	1.50	1.375	2.750	1.69	.66	.50	2.50	MK 581	5/8-11 x 2	228	3.2
		1404-32-32							5/8-11			---	---		
2 1/2	2 1/2	1403-40-40	5.50	2.75	1.75	1.875	3.750	2.12	.94	.50	3.00	MK 1519	7/8-9 x 2 1/2	236	7.4
		1404-40-40							7/8-9			---	---		
3	3	1403-48-48	5.50	2.75	1.75	1.875	3.750	2.62	.94	.50	3.50	MK 1519	7/8-9 x 2 1/2	236	7.0
		1404-48-48							7/8-9			---	---		
3 1/2	3 1/2	1403-56-56	6.00	3.00	1.75	2.125	4.250	3.00	.94	.50	4.00	MK 1577	7/8-9 x 2 1/2	240	10.2
		1404-56-56							7/8-9			---	---		
4	4	1403-64-64	7.00	3.50	2.00	2.500	5.000	3.44	1.06	.50	4.50	MK 1578	1-8 x 3	347	16.5
		1404-64-64							1-8			---	---		
5	5	1403-80-80	8.00	4.00	2.50	3.000	6.000	4.31	1.06	.50	5.62	MK 1579	1-8 x 3 1/2	355	27.0
		1404-80-80							1-8			---	---		
6	6	1403-96-96	10.00	5.00	2.50	3.500	7.000	5.19	1.31	.50	6.75	MK 5533	1 1/4-7 x 4	362	38.8
		1404-96-96							1 1/4-7			---	---		

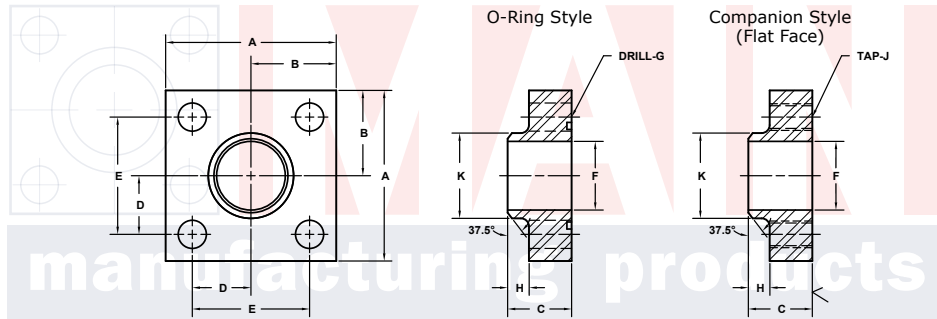
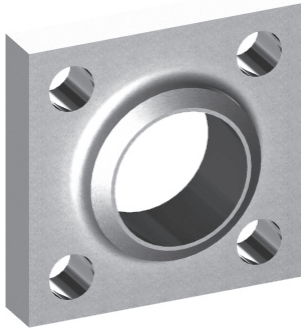

MATERIAL: Low Carbon Steel

Model 1403 / 1405

Model 1404 / 1406

3181 TRI-PARK DR. GRAND BLANC, MI 48439 800-521-7918 810-953-1380 FAX 810-953-1385 INFO@MAINMFG.COM

6000 SERIES SQUARE BOLT PATTERN

FLANGE SIZE	PIPE SIZE	PART NUMBER	A	B	C	D	E	F	G	H	K	MOUNTING KIT®			WT
									J			PART NO.	SCREW SIZE	O-RING	
1/2	1/2	1405-08-08	2.25	1.12	1.50	.719	1.438	.47	.41	.50	.88	MK 2501	3/8-16 x 1 3/4	210	1.5
		1406-08-08							3/8-16			---	---		
3/4	3/4	1405-12-12	2.50	1.25	1.50	.875	1.750	.61	.41	.50	1.12	MK 2502	3/8-16 x 1 3/4	214	1.7
		1406-12-12							3/8-16			---	---		
1	1	1405-16-16	3.00	1.50	1.50	1.000	2.000	.81	.53	.50	1.38	MK 2503	1/2-13 x 2	219	2.5
		1406-16-16							1/2-13			---	---		
1 1/4	1 1/4	1405-20-20	4.00	2.00	1.75	1.375	2.750	1.16	.66	.50	1.75	MK 2504	5/8-11 x 2 1/2	222	5.3
		1406-20-20							5/8-11			---	---		
1 1/2	1 1/2	1405-24-24	4.00	2.00	2.00	1.375	2.750	1.34	.66	.50	2.00	MK 2505	5/8-11 x 2 3/4	225	6.2
		1406-24-24							5/8-11			---	---		
2	2	1405-32-32	5.00	2.50	2.25	1.750	3.500	1.69	.78	.50	2.50	MK 2506	3/4-10 x 3 1/2	228	11.0
		1406-32-32							3/4-10			---	---		
2 1/2	2 1/2	1405-40-40	5.50	2.75	2.25	1.875	3.750	2.12	.94	.50	3.00	MK 2507	7/8-9 x 3 1/2	232	12.8
		1406-40-40							7/8-9			---	---		
3	3	1405-48-48	7.00	3.50	2.50	2.375	4.750	2.62	1.06	.50	3.50	MK 2508	1-8 x 4	236	23.8
		1406-48-48							1-8			---	---		
3 1/2	3 1/2	1405-56-56	8.00	4.00	3.50	2.750	5.500	3.00	1.31	1.00	4.00	MK 2509	1 1/4-7 x 5	342	38.5
		1406-56-56							1 1/4-7			---	---		
4	4	1405-64-64	8.50	4.25	3.50	3.000	6.000	3.44	1.31	1.00	4.50	MK 2510	1 1/4-7 x 5	346	43.0
		1406-64-64							1 1/4-7			---	---		
5	5	1405-80-80	10.00	5.00	4.00	3.625	7.250	4.31	1.56	1.00	5.62	MK 2511	1 1/2-6 x 6	353	69.0
		1406-80-80							1 1/2-6			---	---		

① Order Separately

⑥ Schedules 40, 80 and XXS also Stocked. Other Pipe and Tube Sizes are Available