

# SOCKET WELD PIPE IN-LINE FLANGES

ISO 6164 BOLT PATTERN										250 BAR SERIES																																								
FLANGE SIZE	PIPE SIZE	PART NUMBER	A	B	C	Dmm	E	F	Gmm Jmm	H	K	MOUNTING KIT®			WT																																			
												PART NO.	SCREW SIZE	O-RING																																				
10	3/8	1631-06-06M	4.00	2.00	1.60	98	2.728	1.94	17.5	.62	2.411	MKM 3531	M16 x 65	228	4.9																																			
		1632-06-06M							-----			-----																																						
13	1/2	1631-08-08M							4.75	2.38	1.88	118	3.285	2.44		22.0	.75	2.911	MKM 5573	M20 x 80	232	7.8																												
		1632-08-08M														-----			-----																															
19	3/4	1631-12-12M														5.50	2.75	2.28	145	4.037	2.94		22.0	.75	3.540	MKM 5558	M20 x 90	237	12.8																					
		1632-12-12M																					-----			-----																								
25	1	1631-16-16M																					5.50	2.75	2.28	145	4.037	2.94		22.0	.75	3.540	MKM 5558	M20 x 90	237	12.8														
		1632-16-16M																												-----			-----																	
32	1 1/4	1631-20-20M																												5.50	2.75	2.28	145	4.037	2.94		22.0	.75	3.540	MKM 5558	M20 x 90	237	12.8							
		1632-20-20M																																			-----			-----										
38	1 1/2	1631-24-24M																																			5.50	2.75	2.28	145	4.037	2.94		22.0	.75	3.540	MKM 5558	M20 x 90	237	12.8
		1632-24-24M																																										-----			-----			
51	2	1631-32-32M	5.50	2.75	2.28	145	4.037	2.94							22.0																													.75	3.540	MKM 5558	M20 x 90	237	12.8	
		1632-32-32M													-----																															-----				
56	2 1/2	1631-40-40M							5.50	2.75	2.28	145	4.037	2.94	22.0							.75																						3.540	MKM 5558	M20 x 90	237	12.8		
		1632-40-40M													-----																														-----					
63	3	1631-48-48M													5.50	2.75	2.28	145	4.037	2.94	22.0	.75							3.540															MKM 5558	M20 x 90	237	12.8			
		1632-48-48M																			-----																							-----						

PLEASE USE THE 400 BAR SERIES FOUND BELOW. THE BLOCK SIZE, BOLT PATTERN AND THE O-RING ARE IDENTICAL IN FLANGE SIZES 10 - 38. IF YOU HAVE ANY QUESTIONS PLEASE CALL ENGINEERING AT 1-800-521-7918.

MATERIAL:  
Low Carbon Steel

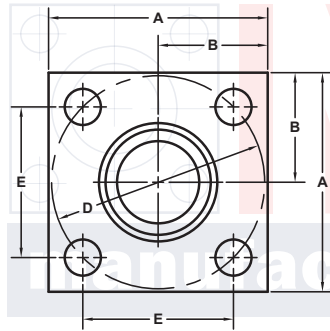
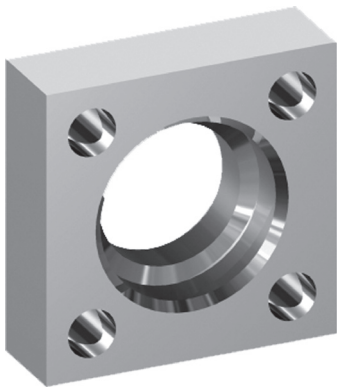

O-Ring Style

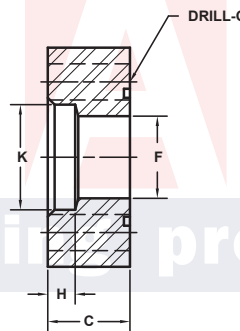

Model 1631 / 1635

Companion Style (Flat Face)

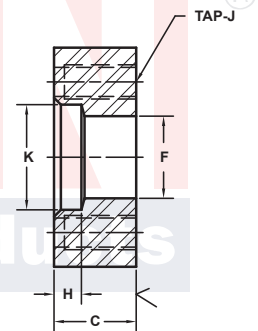

Model 1632 / 1636

3181 TRI-PARK DR. GRAND BLANC, MI 48439 800-521-7918 810-953-1380 FAX 810-953-1385 INFO@MAINMFG.COM

ISO 6164 BOLT PATTERN										400 BAR SERIES					
FLANGE SIZE	PIPE SIZE	PART NUMBER	A	B	C	Dmm	E	F	Gmm Jmm	H	K	MOUNTING KIT®			WT
												PART NO.	SCREW SIZE	O-RING	
10	3/8	1635-06-06M	1.50	.75	.73	35	.974	.44	6.5	.38	.688	MKM 5546	M6 x 30	115	.4
		1636-06-06M							-----			-----			
13	1/2	1635-08-08M	1.75	.88	.81	42	1.170	.50	9.0	.50	.860	MKM 512	M8 x 35	210	.5
		1636-08-08M							-----			-----			
19	3/4	1635-12-12M	2.00	1.00	.90	50	1.392	.75	9.0	.50	1.070	MKM 5559	M8 x 35	214	.7
		1636-12-12M							-----			-----			
25	1	1635-16-16M	2.50	1.25	1.00	62	1.726	1.00	11.0	.50	1.335	MKM 503	M10 x 40	219	1.3
		1636-16-16M							-----			-----			
32	1 1/4	1635-20-20M	3.00	1.50	1.20	73	2.032	1.25	13.5	.50	1.680	MKM 1502	M12 x 50	222	2.2
		1636-20-20M							-----			-----			
38	1 1/2	1635-24-24M	3.50	1.75	1.44	85	2.366	1.50	17.5	.62	1.920	MKM 515	M16 x 60	225	3.4
		1636-24-24M							-----			-----			
51	2	1635-32-32M	4.00	2.00	1.60	98	2.728	1.69	17.5	.62	2.411	MKM 5560	M16 x 65	331	5.0
		1636-32-32M							-----			-----			
56	2 1/2	1635-40-40M	4.75	2.38	1.98	118	3.285	2.12	22.0	.75	2.911	MKM 5538	M20 x 80	335	8.5
		1636-40-40M							-----			-----			
63	3	1635-48-48M	6.00	3.00	2.12	145	4.037	2.32	26.0	.75	3.540	MKM 5561	M24 x 90	337	15.6
		1636-48-48M							-----			-----			
70	3 1/2	1635-56-56M	6.50	3.25	2.46	160	4.454	2.73	26.0	.75	4.045	MKM 5562	M24 x 100	340	21.3
		1636-56-56M							-----			-----			
80	4	1635-64-64M	7.00	3.50	2.85	175	4.872	3.15	33.0	.75	4.550	MKM 5563	M30 x 120	341	26.8
		1636-64-64M							-----			-----			

① Order Separately