

# BLIND FLANGES

## SAE J518 61 SERIES / ISO6162-1 PATTERN

FLANGE SIZE	PIPE SIZE	PART NUMBER	A	B	C	D	E		Gmm	Jmm	MOUNTING KIT <sup>①</sup>			WT
											PART NO.	SCREW SIZE	O-RING	
1/2	NA	1101-08-00M8	1.50	2.12	.75	1.500	.688		8.5		MKM 501	M8 x 30	210	.7
		1102-08-00M8									-----	-----	---	
3/4	NA	1101-12-00M10	1.75	2.62	1.00	1.875	.875		10.5		MKM 502	M10 x 40	214	1.2
		1102-12-00M10									-----	-----	---	
1	NA	1101-16-00M10	2.00	2.82	1.00	2.062	1.031		10.5		MKM 503	M10 x 40	219	1.5
		1102-16-00M10									-----	-----	---	
1 1/4	NA	1101-20-00M10 <sup>+</sup>	2.50	3.19	1.00	2.312	1.188		10.5		MKM 3524	M10 x 40	222	2.0
		1102-20-00M10 <sup>+</sup>									-----	-----	---	
1 1/2	NA	1101-24-00M12 <sup>+</sup>	2.75	3.75	1.25	2.750	1.406		13.0		MKM 3596	M12 x 50	225	3.3
		1102-24-00M12 <sup>+</sup>									-----	-----	---	
2	NA	1101-32-00M12 <sup>+</sup>	3.25	4.00	1.50	3.062	1.688		13.0		MKM 3501	M12 x 55	228	5.2
		1102-32-00M12 <sup>+</sup>									-----	-----	---	
2 1/2 <sup>②</sup>	NA	1101-40-00M12 <sup>+</sup>	4.00	4.50	1.75	3.500	2.000		13.0		MKM 4511	M12 x 60	232	8.5
		1102-40-00M12 <sup>+</sup>									-----	-----	---	
3 <sup>③</sup>	NA	1101-48-00M16	4.50	5.31	2.00	4.188	2.438		17.0		MKM 508	M16 x 75	237	12.8
		1102-48-00M16									-----	-----	---	
3 1/2 <sup>④</sup>	NA	1101-56-00M16	5.00	6.00	1.50	4.750	2.750		17.0		MKM 509	M16 x 65	241	12.3
		1102-56-00M16									-----	-----	---	
4 <sup>④</sup>	NA	1101-64-00M16	5.50	6.38	1.50	5.125	3.062		17.0		MKM 510	M16 x 60	245	14.5
		1102-64-00M16									-----	-----	---	
5 <sup>④</sup>	NA	1101-80-00M16	7.00	7.25	2.00	6.000	3.625		17.0		MKM 511	M16 x 75	253	28.1
		1102-80-00M16									-----	-----	---	

MATERIAL:  
Low Carbon Steel

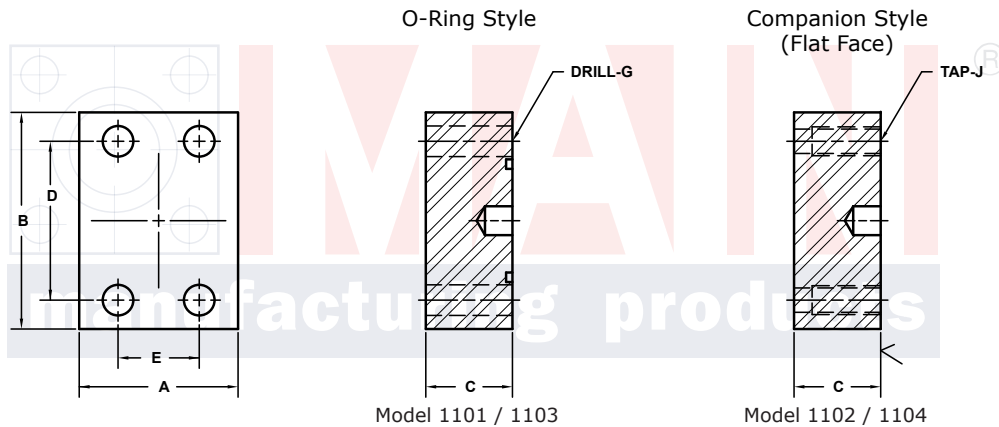

3181 TRI-PARK DR. GRAND BLANC, MI 48439 800-521-7918 810-953-1380 FAX 810-953-1385 INFO@MAINMFG.COM

## SAE J518 62 SERIES / ISO6162-2 PATTERN

FLANGE SIZE	PIPE SIZE	PART NUMBER	A	B	C	D	E		Gmm	Jmm	MOUNTING KIT <sup>①</sup>			WT
											PART NO.	SCREW SIZE	O-RING	
1/2	NA	1103-08-00M8	1.75	2.22	1.00	1.594	.718		8.5		MKM 512	M8 x 35	210	.9
		1104-08-00M8									-----	-----	---	
3/4	NA	1103-12-00M10	2.00	2.81	1.00	2.000	.937		10.5		MKM 502	M10 x 40	214	1.4
		1104-12-00M10									-----	-----	---	
1	NA	1103-16-00M12	2.25	3.19	1.00	2.250	1.093		12.5		MKM 513	M12 x 45	219	1.8
		1104-16-00M12									-----	-----	---	
1 1/4	NA	1103-20-00M12 <sup>+</sup>	2.75	3.75	1.25	2.625	1.250		13.0		MKM 1502	M12 x 50	222	3.3
		1104-20-00M12 <sup>+</sup>									-----	-----	---	
1 1/2	NA	1103-24-00M16	3.25	4.50	1.50	3.125	1.437		17.0		MKM 515	M16 x 60	225	5.7
		1104-24-00M16									-----	-----	---	
2	NA	1103-32-00M20	4.00	5.25	1.75	3.812	1.750		21.0		MKM 516	M20 x 70	228	9.7
		1104-32-00M20									-----	-----	---	
2 1/2	NA	1103-40-00M24	5.00	6.88	2.00	4.875	2.312		25.5		MKM 517	M24 x 80	232	18.2
		1104-40-00M24									-----	-----	---	
3	NA	1103-48-00M30	6.00	8.50	2.50	6.000	2.812		32.0		MKM 518	M30 x 110	237	33.5
		1104-48-00M30									-----	-----	---	

① Order Separately    ② 2500 PSI Max    ③ 2000 PSI Max    ④ 500 PSI Max

NOTE: DIMENSIONS ARE IN INCHES UNLESS OTHERWISE NOTED. + Also Available for M12 Bolts    † Also Available for M14 Bolts

© Copyright MAIN Mfg. 2017